

*What
do
you
want?*

GOOD SPORT

*To feel like I have all the answers, even if
I don't.*

*To see things get better for my brother.
He's had a rough few years trying to finish
school. He's finally done, but can't seem
to find a job that he feels suited in. I want
things for him to really turn around. A
new positive direction in his life!*

*A wood burning oven and the skills to
operate it.*

To sell my art. Even if it's only for a few cents! Just to get that feeling of satisfaction for making something that another individual liked.

To support my community.

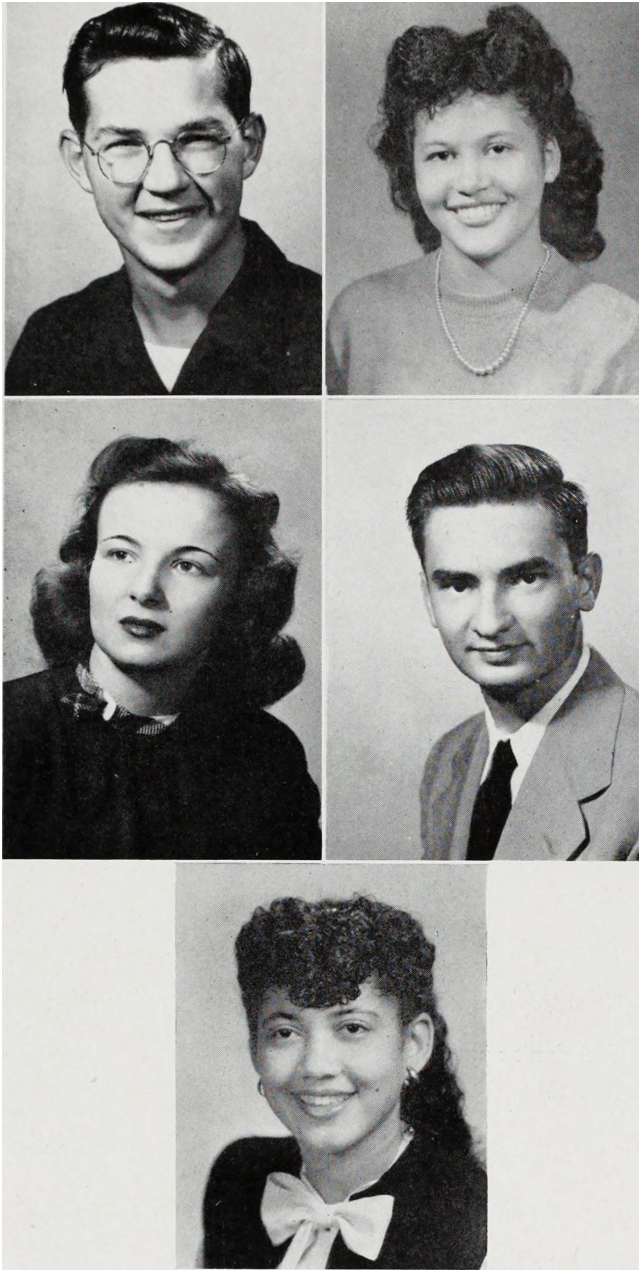

A cure for depression.

A full-time job.

Love & enough money to do what I need to do, all their positive wishes to come true - the ones that make the most sense and allow for life to continue to be good, to get through the next year and come up with something exciting, research, research, research gold, eradicate stupidity.

*Young professionals sitting down and
having lunch in Market Lane.*

A jawline.

For my passion for music to return.

A pug.

"Pug"
Wikipedia (Retrieved 30 May 2015)

The Pug is a breed of dog with a wrinkly, short-muzzled face and curled tail. The breed has a fine, glossy coat that comes in a variety of colours, most often fawn or black, and a compact square body with well-developed muscles.

Pugs were brought from China to Europe in the sixteenth century and were popularized in Western Europe by the House of Orange in the Netherlands, and the House of Stuart. [2] In the United Kingdom in the nineteenth century Queen Victoria developed a passion for Pugs which she passed on to other members of the Royal family.

Known for being sociable and gentle companion dogs,[3] Pugs remain popular into the twenty-first century, with some famous celebrity owners. A Pug was judged Best in Show at the World Dog Show in 2004.

While the Pugs that are depicted in eighteenth century prints tend to be long and lean,[2] modern breed preferences are for a square cobby* body, a compact form, a deep chest, and well-developed muscle.[4] Their smooth and glossy coats can be fawn, apricot fawn, silver fawn or black.[4][5] The markings are clearly defined and there is a trace of a black line extending from the occiput to the tail.[4] The tail normally curls tightly over the hip.[2]

Pugs have two distinct shapes for their ears, "rose" and "button". "Rose" ears are smaller than the standard style of "button" ears, and are folded with the front edge against the side of the head. Breeding preference goes to "button" style ears.[6]

Pugs' legs are very strong, straight, of moderate length, and are set well under. Their shoulders are moderately laid back. Their ankles are strong, their feet are small, their toes are well split-up, and their nails are black.[4] The lower teeth normally protrude further than their upper, resulting in an under-bite.[1]

The breed is often described as *multum in parvo*, or "much in little", alluding to the Pug's remarkable personality, despite its small size.[1] Pugs are strong-willed but rarely aggressive, and are suitable for families with children. The majority of the breed is very fond of children and sturdy enough to properly play with them. Depending on their owner's mood, they can be quiet and docile but also vivacious and teasing.[7] Pugs tend to have a lazy nature and spend a lot of time napping. They are often called "shadows" be-

cause they follow their owners around and like to stay close to the action,[8] craving attention and affection from their owners.[9] [10]

The early history of the Pug is not attested to in detail; it is accepted that modern Pugs are descended from dogs imported to Europe from China in the 16th century. Similar dogs were popular in the Imperial court during the Song Dynasty.[11]

Pugs were popular at European courts, and reportedly become the official dog of the House of Orange in 1572 after a Pug named Pompey saved the life of the Prince of Orange by alerting him to the approach of assassins.[1]

A Pug travelled with William III and Mary II when they left the Netherlands to accept the throne of England in 1688.[2] During this period, the Pug may have been bred with the old type King Charles spaniel, giving the modern King Charles Spaniel its Pug characteristics.[12]

The breed eventually became popular in other European countries as well. Pugs were painted by Goya in Spain, and in Italy they rode up front on private carriages, dressed in jackets and pantaloons that matched those of the coachman. They were used by the military to track animals and people, and were also employed as guard dogs.[2]

The English painter William Hogarth was the devoted owner of a series of Pugs. His 1745 self-portrait, which is now in London's Tate Gallery, includes his Pug, Trump.[13] The Pug was also well known in Italy. In 1789, a Mrs. Piozzi wrote in her journal, "The little Pug dog or Dutch mastiff has quitted London for Padua, I perceive. Every carriage I meet here has a Pug in it." [14] The popularity of the Pug continued to spread in France during the eighteenth century. Before her marriage to Napoleon Bonaparte, Joséphine had her Pug Fortune carry concealed messages to her family while she was confined at Les Carmes prison, it having alone been given visiting rights.[15]

In nineteenth century England, the breed flourished under the patronage of Queen Victoria. Her many Pugs, which she bred herself, included Olga, Pedro, Minka, Fatima and Venus.[2] Her involvement with dogs in general helped to establish the Kennel Club, which was formed in 1873.[2] Queen Victoria favoured apricot and fawn colors. Her passion for Pugs was passed on to many other members of the Royal family, including her grandson King George V [16] and his son King Edward VIII. Many responded to

the breed's image of anti-functionalism and diminutive size during this period.[17] In paintings and engravings of the 18th and 19th centuries, Pugs usually appear with longer legs and noses than today, and sometimes with cropped ears. The modern Pug's appearance probably changed after 1860 when a new wave of Pugs was imported directly from China. These Pugs had shorter legs and the modern-style Pug nose. The British aristocrat Lady Brassey is credited with making black Pugs fashionable after she brought some back from China in 1886.[1] [2] Ear cropping was made illegal in 1895. [18]

Pugs arrived in the United States during the nineteenth century and were soon making their way into the family home and the show ring.[2] The American Kennel Club recognized the breed in 1885. The Pug Dog Club of America was founded in 1931 and was recognized by the American Kennel Club that same year. In 1981, the Pug Dhandys Favorite Woodchuck won the Westminster Kennel Club Dog Show in the United States, the only Pug to have won there since the show began in 1877.[19] The World Champion, or Best in Show at the 2004 World Dog Show held in Rio de Janeiro, Brazil, was a Pug named Double D Cinoblu's Masterpiece.[20]

Since Pugs lack longer snouts and prominent skeletal brow ridges, they are susceptible to eye injuries such as proptosis, scratched corneas, and painful entropion.[2] They also have compact breathing passages, leaving many prone to breathing difficulties or unable to efficiently regulate their temperature through evaporation from the tongue by panting. A Pug's normal body temperature is between 101 °F (38 °C) and 102 °F (39 °C). If this temperature rises to 105 °F (41 °C), oxygen demand is greatly increased and immediate cooling is required. If body temperature reaches 108 °F (42 °C), organ failure can occur.[21] Their breathing problems can be worsened by the stresses of travelling in air cargo, which may involve high temperatures. Following the deaths of Pugs and other brachycephalic breeds, several airlines either banned their transport in cargo or enacted seasonal restrictions.[22] [23]

Pugs that live a mostly sedentary life can be prone to obesity, though this is avoidable with regular exercise and a healthy diet.[24] The median life span of Pugs is 11 years, which is in line with other breeds of the same size.[25]

Pugs, like other short-snouted breeds, have

elongated palates. When excited, they are prone to "reverse sneezing" which causes them to quickly (and seemingly laboriously) gasp and snort. The veterinary name for this is pharyngeal gag reflex and it is caused by fluid or debris getting caught under the palate and irritating the throat or limiting breathing. Reverse sneezing episodes are usually not harmful, and massaging the dog's throat or covering its nose in order to make it breathe through its mouth can often shorten a sneezing fit.[26]

Some pugs are also born with stenotic nares which can also inhibit their breathing. In serious cases, the pinched nostrils make breathing even more difficult for this breed and put added pressure on the larynx.[27] In some cases, the dog could pass out from blocked airways. If this happens, one should inquire with their veterinarian whether or not surgery is needed to modify the breathing passages.[28]

Eye prolapse is a common problem among Pugs and other brachycephalic breeds (see Brachycephalic syndrome)[29] and can be caused by a trauma to the head or neck, or even by the owner using a tight leash instead of a harness.[30] While the eye can usually be pushed back into its socket by the owner or by a vet, veterinary attention is usually advisable. If the prolapse happens on a regular basis, the Pug might require surgery.[31]

Pugs have many wrinkles in their faces, so owners will often clean inside the creases to avoid irritation and infection.[32] If this is not done, the dog may develop a condition known as skin fold dermatitis.[33]

An abnormal formation of the hip socket, known as hip dysplasia, affected nearly 64% of Pugs in a survey performed by the Orthopedic Foundation for Animals; the breed was ranked the second worst-affected by this condition out of 157 breeds tested.[34]

Pugs are one of several breeds that are more susceptible than other dogs to demodectic mange, also known as "demodex". This condition is caused when parasitic mites, that are often present in a dog's skin without causing symptoms, are allowed to do damage because their host has a weakened immune system. It is a problem for many young Pugs, although not usually a major one, and is easily treatable, but some are especially susceptible and present with a systemic form of the condition.[35] This vulnerability is thought to be genetic and breeders will avoid producing pup pies from adults who have this condition.[36] In 2008, an investigative documentary carried out by the

BBC found significant inbreeding between pedigree dogs, with a study by Imperial College, London, showing that the 10,000 Pugs in the UK are so inbred that their gene pool is the equivalent of only 50 individuals.[37]

Pugs can suffer from necrotizing meningoencephalitis (NME), also known as Pug dog encephalitis (PDE), an inflammation of the brain and meninges.[38] NME also occurs in other small dogs, such as the Yorkshire Terrier, Maltese, and Chihuahua.[38] There is no known cure for NME, which is believed to be an inherited disease.[39] Dogs usually die or have to be put to sleep within a few months of onset, which, in those susceptible to this condition, is typically between six months and seven years of age.[40]

This breed, along with other brachycephalic dogs (e.g., boxers, bulldogs), are also prone to hemivertebrae.[41][42] The curled tail of a British bulldog is an example of a hemivertebrae, but when it occurs not in the coccygeal vertebrae but in other areas of the spine, it can cause paralysis. The condition occurs when two parts of a spinal vertebra do not fuse properly while a young Pug is still growing, resulting in an irregularly shaped spinal cavity which can put pressure on the spinal cord.[43]

* The canine body may be described as "cobby" (short and square) or sometimes by a ratio of height to length.

REFERENCES

1. "American Kennel Club - Pug History". AKC.org. American Kennel Club. Retrieved 19 August 2006.
2. Farr, Kendall; Montague, Sarah (1999). *Pugs in Public*. New York: Stewart, Tabori & Chang, a division of U.S. Media Holdings. ISBN 1-55670-939-0.
3. Morn, September (2010). *Our Best Friends: The Pug*. Pittsburgh: ElDorado Ink. p. 11. Retrieved 2 April 2015.
4. "American Kennel Club - Pug". AKC.org. op. cit. Retrieved 14 October 2008.
5. Color: The colors are fawn or black. The fawn color should be decided so as to make the contrast complete between the color and the trace and mask.
6. "Ears". Pugs.org. Pug Dog Club of America. Retrieved 14 October 2008.
7. "Pug Temperament and Personality". PugInformation.org. Retrieved 26 December 2009.
8. "Pug - Temperament & Personality". www.petwave.com. PetWave Corporation. Retrieved 13 July 2014.
9. "Pugminded: Personality". pugminded.com.
10. Belmonte, Brenda (2004). *The Pug Handbook*. New York: Barron's Educational Series Inc. p. 13.
11. Collier, V. W. F. (1921). *Dogs of China & Japan, in Nature and Art*. W. Heinemann, London. p. 147. "The Lo-chiang dog was a "pai" dog and consequently small, "short-headed," and "short-legged" before A.D. 1000. It was very possibly the Chinese Pug and appears to have been fashionable at the Chinese court from the beginning of the eighth century to the middle of the eleventh century possibly even to the removal of the capital from Hsianfu to Peking, about A.D. 1153."
12. Moffat, Norma. *Cavalier King Charles Spaniel: Your Happy Healthy Pet* (2nd ed.). Howell Book House. p. 19. ISBN 0-471-74823-4.
13. William Hogarth. *The Painter and his Pug, 1745*. Tate Gallery, London, England. www.tate.org.uk. Retrieved 9 April 2013.
14. Maggitti, Phil (2000). *Pugs: Everything about Purchase, Care, Nutrition, Behavior, and Training*. Barron's Educational Series. p. 10. ISBN 978-0-7641-1045-0. Retrieved 17 January 2010.
15. Katharine Macdonogh (August 1996). "Prison Pets in the French Revolution". History Today 46.
16. Royal Collection - *The Duke of York Holding a Pug*
17. Yang, C. (2012). *Culture in Miniature: Toy Dogs and Object Life. Eighteenth Century Fiction*, 25(1), 139-174.
18. "Pugs in Art". The Bulldog Information Library. Retrieved 17 January 2010.
19. Cunliffe, Juliette. "History of the Pug". DogChannel.com. Retrieved 26 December 2009.
20. "Pug Wins World Championship Show". PugNews.com. 20 April 2004. Retrieved 26 December 2009.
21. "Keeping your Pug cool during the dog days of summer". OwnedByPugs.com. 18 July 2005. Retrieved 26 December 2009.
22. "Air Travel and Short-Nosed Dogs FAQ". American Veterinary Medical Association. Retrieved 7 July 2014.
23. Haughney, Christine (26 October 2011). "Banned by Many Airlines, These Bulldogs Fly Private". The New York Times. Retrieved 7 July 2014.
24. "Obesity in Pugs". PugInformation.org. Retrieved 26 December 2009.
25. "2004 KC/BSAVA Purebred Dog Health Survey" (PDF). Retrieved 4 August 2010.
26. Lundgrun, Becky (26 June 2006). "Reverse Sneezing (Pharyngeal Gag Reflex)". VeterinaryPartner.com. Retrieved 26 December 2009.
27. "Brachycephalic Airway Obstruction Syndrome". Genetic Welfare Problems of Companion Animals. ufaw.org.uk: Universities Federation for Animal Welfare. Retrieved 11 September 2014.
28. "Stenotic Nares in Dogs". Pet Health Network. 29 August 2012. Retrieved 26 October 2014.
29. "Brachycephalic Ocular Syndrome". Genetic Welfare Problems of Companion Animals. ufaw.org.uk: Universities Federation for Animal Welfare. Retrieved 11 September 2014.
30. Dogs 101: Pug Video, Animal Planet.
31. *Traumatic eye prolapse* by Jeff Grognet, D.V.M., B.Sc.(Agr.)
32. "Pug Health Guide". Pugs.org. op. cit. Retrieved 14 October 2008.
33. "Skin Fold Dermatitis". Genetic Welfare Problems of Companion Animals. ufaw.org.uk: Universities Federation for Animal Welfare. Retrieved 11 September 2014.
34. "Hip Dysplasia Statistics: Hip Dysplasia by Breed". OFFA.org. Ortheopedic Foundation for Animals. Retrieved 14 October 2010.
35. "Demodex Mange in Pugs". PugVillage.com. Retrieved 26 December 2009.
36. "Demodectic Mange in Dogs". PetMD

- Article by T. J. Dunn, Jr., DVM. Retrieved 9 April 2013.
37. "Pedigree dogs plagued by disease". BBC News. 19 August 2008. Retrieved 26 December 2009.
38. Cynthia M. Kahn, BA, MA, ed. (2010). *The Merck Veterinary Manual* (10th ed.). Kendallville, Indiana: Courier Kendallville, Inc. pp. 1119, 1158. ISBN 0-911910-93-X.
39. "Slide 1". Pugs.org. op. cit. Retrieved 14 October 2008.
40. "Pug Dog Encephalitis". PugPlace.com. Retrieved 26 December 2009.
41. "Hemivertebrae". Genetic Welfare Problems of Companion Animals. ufaw.org.uk: Universities Federation for Animal Welfare. Retrieved 11 September 2014.
42. "Hemivertebrae". barkbytes.com. Retrieved 14 October 2008.
43. "Pug Health Management". MyDog-Breed.com. Retrieved 26 December 2009.

I wanna rock your gypsy soul.

To be able to afford to buy artwork.

*The perfection that is Ryan Gosling to be
my husband.*

A gaming computer and to go to Tokyo.

A clean house.

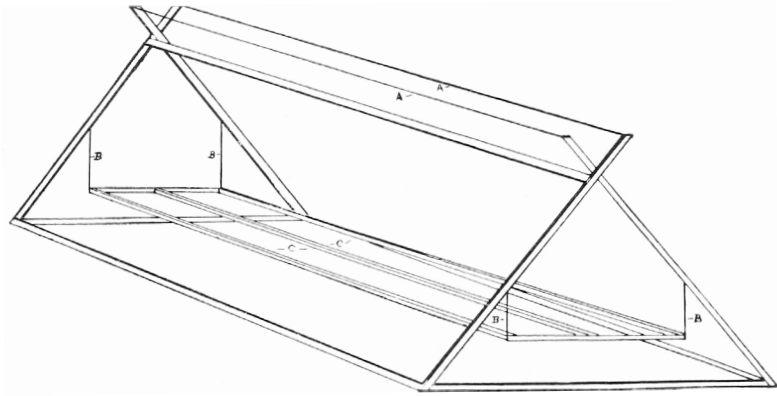

*Time travel, second chances, and
do-overs.*

A good man and a beach house.

I want Farhi to stop buying everything.

**A
SATISFIED
TENANT
IS OUR
GREATEST
ASSET**

- FARHI HOLDINGS CORPORATION

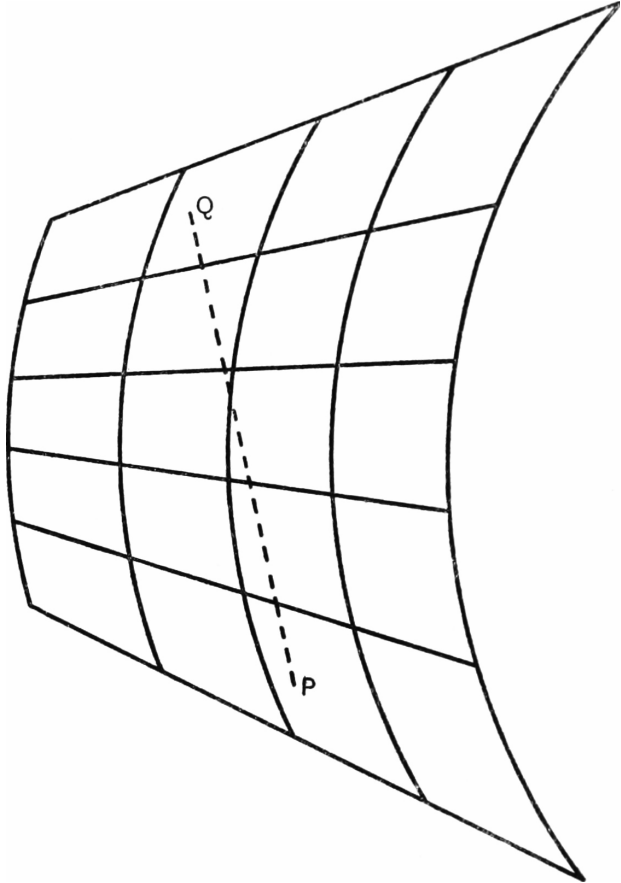

More time.

Eclectic music and safe spaces ... something otherly, where we all know each other's faces.

To be a lighthouse keeper, to read and be left alone.

Home \ Away ^[1]	ARS	AST	BIR	BLB	BLP	BOL	CHE	DER	GRI	HUD	LEE	LEI	LIV	MCI	MUN	MID	NEW	POR	SHU	SHW	SUN	WHU
Arsenal	5-2	1-1	3-2	7-1	5-0	2-1	6-3	9-1	0-0	3-1	4-1	3-1	3-1	4-1	5-3	1-2	1-1	1-1	2-0	1-3	1-1	
Aston Villa	5-1	1-1	5-2	4-1	3-1	3-3	4-6	2-0	6-1	4-3	4-2	4-2	4-2	7-0	8-1	4-3	2-2	4-0	2-0	4-2	6-1	
Birmingham City	2-4	0-4	4-1	1-1	0-2	6-2	1-2	4-1	2-0	0-1	2-1	2-0	3-2	0-0	1-2	1-1	2-1	3-1	2-0	1-0	0-2	
Blackburn Rovers	2-2	0-2	2-1	4-1	5-0	2-2	2-0	5-2	5-3	3-1	3-0	3-3	0-1	4-1	4-5	1-0	1-2	2-1	5-2	3-0	1-0	
Blackpool	1-4	2-2	0-1	1-1	3-3	2-1	2-1	1-0	3-1	1-1	3-7	5-4	1-3	2-2	5-1	3-2	0-0	2-2	2-1	0-4	3-1	
Bolton Wanderers	1-4	1-1	2-0	1-1	1-0	3-3	1-1	1-2	4-2	1-0	2-0	4-1	2-0	1-1	3-1	3-0	0-3	3-1	6-2	2-2	2-2	
Chelsea	1-5	0-2	1-0	3-2	3-0	0-1	1-1	5-0	1-2	1-0	1-0	1-0	2-2	2-0	6-2	4-0	1-1	2-0	1-0	0-0	5-0	
Derby County	4-2	1-1	0-0	1-1	3-2	4-1	6-2	1-0	4-1	4-1	1-0	2-2	1-1	6-1	1-2	1-5	5-1	4-3	2-3	2-3	4-1	
Grimsey Town	0-1	1-2	4-1	2-0	6-2	4-1	0-1	5-3	2-1	2-0	8-2	0-0	3-5	2-1	4-1	2-2	0-3	2-1	2-3	2-1	4-0	
Huddersfield Town	1-1	1-6	1-0	1-1	10-1	3-2	1-1	3-0	2-2	3-0	4-1	2-1	1-1	3-0	2-2	0-3	1-3	1-1	1-1	1-1	2-0	
Leeds United	1-2	0-2	3-1	4-2	2-2	3-1	2-3	3-1	0-0	1-2	1-3	1-2	4-2	5-0	7-0	1-0	2-2	4-0	2-3	0-3	3-0	
Leicester City	2-7	4-1	2-1	3-1	6-0	2-1	2-1	1-1	0-1	1-2	4-0	3-1	3-2	5-4	0-3	3-1	3-1	2-2	2-5	1-1	1-1	
Liverpool	1-1	1-1	0-0	2-1	5-2	7-2	3-1	0-0	1-1	1-4	2-0	3-1	0-2	1-1	4-1	4-2	3-1	6-1	1-2	2-4	2-0	
Manchester City	1-4	3-1	4-2	3-0	2-4	3-0	2-0	4-3	1-0	0-1	1-0	0-2	1-1	4-1	4-2	2-0	1-3	0-4	2-0	2-0	1-1	
Manchester United	1-2	3-4	2-0	0-1	0-0	1-1	1-0	2-1	0-2	0-6	0-0	0-0	4-1	1-3	4-4	4-7	0-1	1-2	4-1	1-1	1-0	
Middlesbrough	2-5	3-1	1-1	4-1	5-1	3-0	2-2	4-1	2-1	2-3	5-0	2-2	3-3	4-1	3-1	3-1	0-1	4-1	2-0	1-0	2-2	
Newcastle United	1-3	2-0	2-2	2-3	0-2	4-0	1-0	2-5	1-2	1-1	4-1	5-2	0-4	0-1	4-3	0-5	4-7	1-0	1-2	2-0	4-2	
Portsmouth	1-1	5-0	2-2	3-0	4-3	1-0	1-1	2-0	4-3	2-2	1-1	2-1	4-0	1-1	4-1	1-0	1-2	2-3	2-4	1-1	2-0	
Sheffield United	1-1	3-4	3-1	1-1	5-1	2-0	4-0	3-3	2-1	0-2	1-1	0-2	4-1	2-2	3-1	4-2	3-1	3-1	1-1	3-3	1-2	
Sheffield Wednesday	1-2	3-0	9-1	1-3	7-1	1-0	1-1	3-2	4-1	2-1	2-1	4-0	3-5	1-1	3-0	3-2	2-1	2-2	1-3	7-2	5-3	
Sunderland	1-4	1-1	1-0	8-2	2-4	3-1	2-0	1-3	3-2	4-2	4-0	2-5	6-5	3-3	1-2	1-1	5-0	0-0	2-1	5-1	6-1	
West Ham United	2-4	5-5	1-2	4-3	3-2	1-4	4-1	0-1	3-4	2-1	1-1	2-0	7-0	2-0	5-1	0-3	3-2	4-3	4-1	3-3	0-3	

First Division results from the 1930-31 Football League Championships, where Arsenal ranked first for the first time since its founding in 1886. Source: Wikipedia, "1930-31 Football League."

A championship for Arsenal Football Club in the next five years.

To be remembered on a national scale, a contributor to Canadian culture.

A clean slate.

To figure out my future education and career plans. It's amazing how adulthood creeps up on you. I wish I could be a child again where the most I had to worry about was what to play at recess.

For my dog to live as long as I do.

Chips, usually just chips.

A car for my mom.



It was a broken down \$1000 car.



To be consistently content.

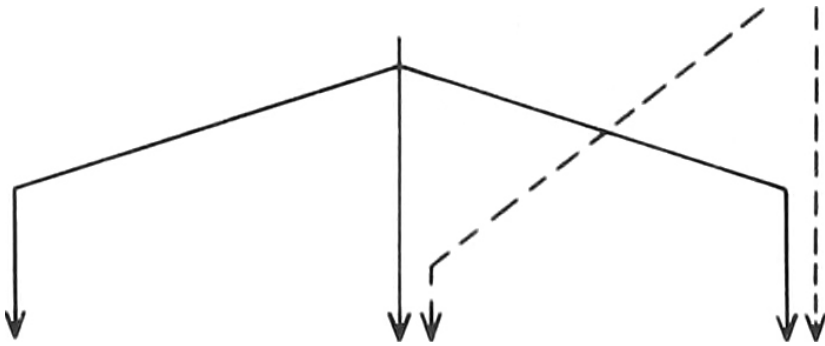

Authentic yet affordable goods.

James' back to stop hurting.

More love and acceptance in the world for people of every race, sexual orientation, and gender. People need to stop judging and hating one another. We are all human beings so please show respect for everyone. Don't be ignorant. Listen, ask questions, research, and learn.

More new music from Brand New.



*To sit on your lap
like the red-faced girl
next door*

To see danger from a safe vantage!!!

To be the loser-in-residence.

To die young even when I am old.

A stream to come in the kitchen window at breakfast time. It will be a stream that spills cool cleansing water over the kitchen table, moving away the dirty plates and bowls. I want the floor to become rounded black pebbles as the water carves a path in the tile. I want to follow the stream, and find an unseen room in the home. I want to clear cobwebs from the shabby and unfashionable golden walls and wonder, "who was last in here?" I want to find what they left for us.

PUPILS IN SPECIFIED OCCUPATION.	
Number.	Per Cent.
349	40.5
230	26.7
103	12.0
23	2.7
137	15.9
19	2.2
861	100.0

To worry less about student loans/university fees and get a good paying summer job. I wish there were more employment opportunities for students. Competition is so tough, that finding a summer job is almost near impossible.

*To sleep better, be more productive, and
stop thinking about him.*

*An overhaul of the schooling system in
Canada.*

*The construction in my city to be finished!
Seriously it's been like this since 2013...
show me some results please.*

*To find my place in the art world. Where
my work is best suited. What I'm really
passionate about, and pursue that love
into a specific art career.*

New seashells.

Respect in the classroom and for students to stop throwing so much shade at each other. We are here to learn, improve our work, and get our degrees. Everyone should support each other instead of looking down at one another.

To be closer to...

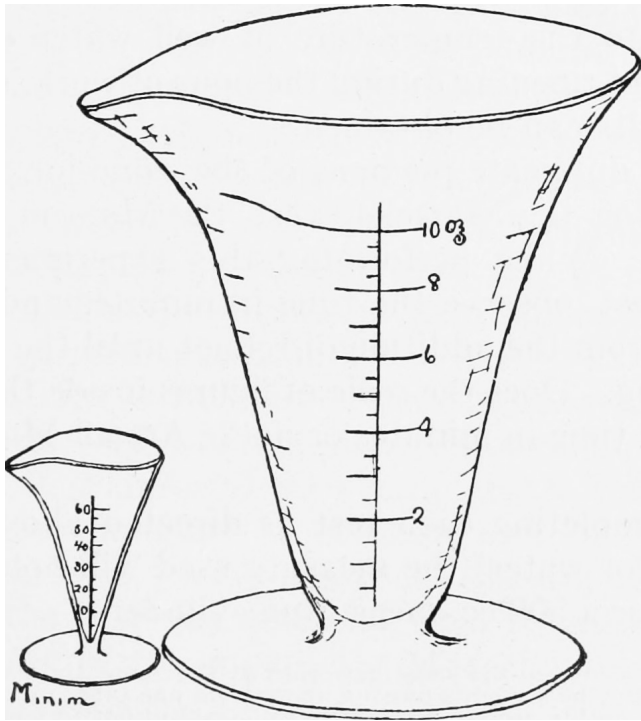

*4 tables and 8 chairs. 2 types of beer and
1 type of liquor. And curtains and nice
music.*

My back to stop hurting.

*To break free; to dance with somebody; to
be anarchy; to be sedated.*

Images

U and I, page 22. Urbana, Ill.: University of Illinois High School, 1961.

Woods, Prince Tannat. *Open-air Poultry Houses for All Climates; A Practical Book on Modern Common Sense Poultry Housing for Beginners and Veterans in Poultry Keeping. What to Build and How to Do It. Houses that Will Promote Health, Vigor and Vitality in Laying and Breeding Stock*, page 80. Chicago, Ill.: American Poultry Journal Publishing Co., 1912.

Eddington, Arthur Stanley, Sir. *Space, Time and Gravitation: An Outline of the General Relativity Theory*, page 113. Cambridge: The University Press, 1920.

Robert Sims YouTube channel, "Kids buy mom a car"; IronmanDavidYang YouTube channel, "New Car Surprise for Mom on Mother's Day"; gkadish YouTube channel: "I made my mother cry today"; Corey Wadden YouTube channel: "Son Buys Mom Her Dream Car (And Surprises Her With It)";

2nd Interagency Workshop on In-Situ Water-Quality Sensing: Biological Sensors, Pensacola Beach, Florida, April 28-30, 1980, page 108. Washington (?): U.S. Department of Commerce; National Oceanic and Atmospheric Association, 1981.

American Homes and Gardens, page 291. New York: Munn and Co., 1905.

The Public Schools and Women in Office Service, page 69. Boston, Mass: Women's Educational and Industrial Union, 1914.

Sammis, John Langley and John Wright Decker. *Cheese Making; A Book for Practical Cheese-makers, Factory Patrons, Agricultural Colleges and Dairy Schools*, page 42. Madison, Wis: Mendota Book Company, 1918.

This book is compiled of anonymous contributions from London, ON residents for the official opening of Good Sport on June 5, 2015.
Designed by Ruth Skinner.

What do you want?
Published by Good Sport
256 Richmond St., Unit 2
London, ON N6B 2H7
cargocollective.com/goodsport

ISBN 978-0-9947993-0-2 (bound)
Edition of 15

